

● **Outer dimensions (mm)**

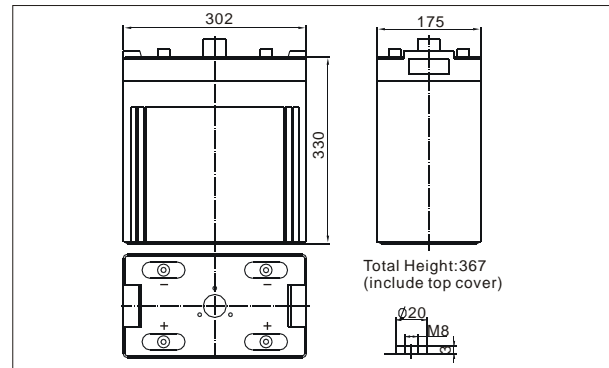

TianChang sealed lead-acid rechargeable battery (VRLA battery) is leak-proof and maintenance free. The Superiority of VRLA battery is derived from its uniquely efficient oxygen recombination technology. The oxygen evolved from the positive plates diffuses through the micro porous glass fiber mat to the negative plates where it is changed back to water by recombination reaction, eliminating the need for water addition. The result is a maintenance free battery.

● **Battery Construction**

Component	Positive plate	Negative plate	Container	Cover	Safety valve	Terminal	Separator	Electrolyte
Raw material	Lead dioxide	Lead	ABS	ABS	Rubber	Copper	Fiberglass	Sulfuric acid

● **General Features**

- Absorbent Glass Mat (AGM) technology for efficient gas recombination of up to 99% and freedom from electrolyte maintenance or water adding.
- Not restricted for air transport-complies with IATA/ICAO Special Provision A67.
- UL-recognized component.
- Can be mounted in any orientation.
- Computer designed lead, calcium tin alloy grid for high power density.
- Long service life, float or cyclic applications.
- Maintenance-free operation.
- Low self discharge.

● **Application**

- Medical Equipment
- Cable Television
- Control Equipment
- UPS
- Communication Equipment
- Emergency power System
- Security System

● **Specifications**

Nominal Voltage		2V
Capacity (10 hr 25°C)		600Ah
Design Life		20 Years
Dimensions	Length	302 mm (11.89 inch)
	Width	175 mm (6.89 inch)
	Height	330 mm (12.99 inch)
	Total Height	367 mm (14.45 inch)
Approx. Weight		37 Kg
Capacity 25°C (77°F)	10 hr rate	600Ah
	3 hr rate	480Ah
	1 hr rate	390Ah
Internal Resistance (Full charged Battery at 25°C (77°F))		0.32m Ω
Capacity affected by Temperature (20hr)	40°C	102%
	25°C	100%
	0°C	85%
	-15°C	65%
Self-Discharge at 25°C	3 month	Remaining capacity: 91%
	6 month	Remaining capacity: 82%
	12 month	Remaining capacity: 65%
Normal operating temperature		25°C ± 3°C (77°F ± 5°F)
Operating temperature range		-15°C ~ 50°C (5 ~ 122°F)
Float charging voltage (25°C)		2.27 to 2.30V
Cyclic charging voltage (25°C)		2.42 to 2.48V
Maximum charging current		120A
Terminal material		Copper
Maximum Discharge current		4200A (5sec)

TC2-600

Charge characteristic Curve for standby use

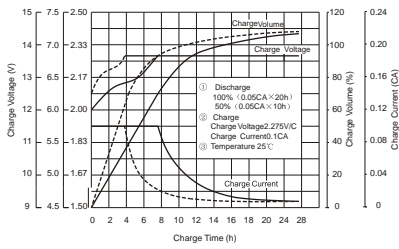

Discharge characteristic (25°C/77°F)

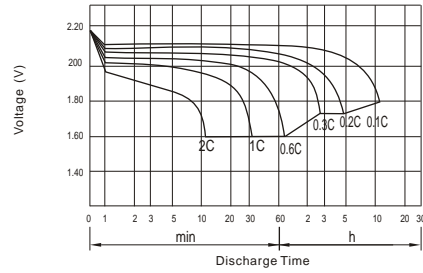

Relationship between charging voltage and temperature

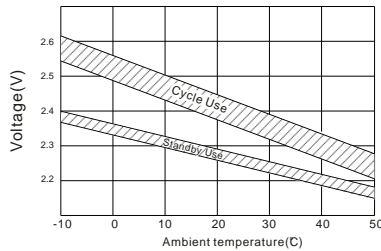

Self-discharge characteristic

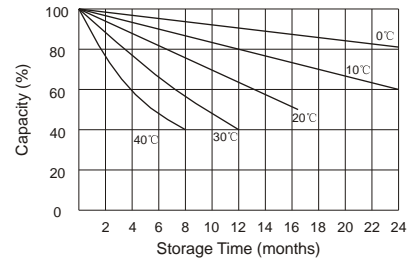

Temperature effects on float life

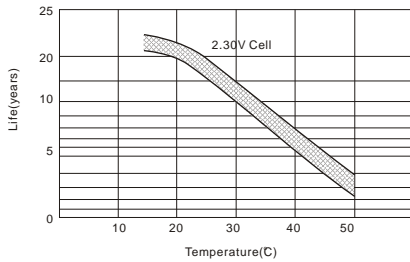

Temperature effects on capacity

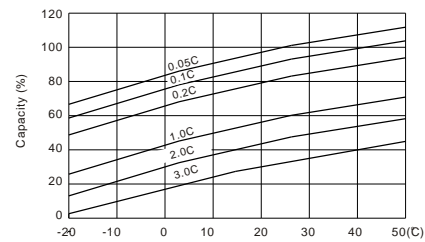

Life characteristics of Standby use

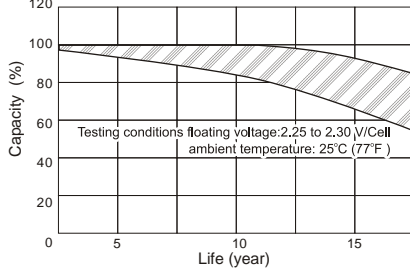

Cycle service life in relation to depth of discharge

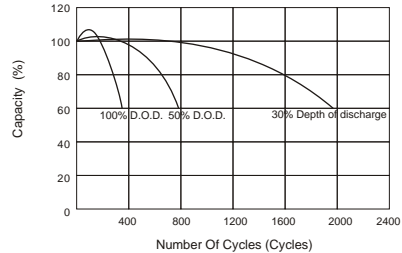

Discharge Constant Current (Amperes at 77°F/25°C)

End Point Volts/Cell	10min	15min	30min	45min	1h	3h	5h	10h
1.60V	1161	887	618	480	364	186	115	65
1.65V	1101	844	590	461	351	181	113	64
1.70V	1038	800	562	440	337	174	111	63
1.75V	974	755	533	419	322	167	108	61
1.80V	909	710	503	397	307	160	105	60

Discharge Constant Power (Watts at 77°F/25°C)

End Point Volts/Cell	10min	15min	30min	45min	1h	2h	3h	5h
1.60V	1911	1424	1123	905	710	483	358	225
1.65V	1800	1347	1067	864	680	472	349	222
1.70V	1688	1269	1009	820	649	460	340	218
1.75V	1577	1191	951	776	617	446	330	214
1.80V	1467	1112	892	731	583	418	309	211

All mentioned characteristics data are average values.