

TC12-100-FG

(12V100Ah/10hr)



GEL Series is GEL battery which is manufactured with AGM separator and colloidal Silicon. Gel battery are featured with low self-discharge, strong ability to recover from deep discharging, excellent cycle life and performance at cold ambient temperatures than conventional VRLA.

Battery Construction

Component	Positive plate	Negative plate	Container	Cover	Safety valve	Terminal	Separator	Electrolyte
Raw material	Lead dioxide	Lead	ABS	ABS	Rubber	Copper	Fiberglass	Colloidal silicon

General Features

- Micro millimeter SiO₂ and H₂SO₄ technology for Efficient gas recombination of up to 99% and Freedom from electrolyte maintenance or water adding.
- Not restricted for air transport-complies with IATA/ICAO Special Provision A67.
- UL-recognized component.
- Can be mounted in any orientation.
- Computer designed lead, calcium tin alloy grid for high power density.
- Long service life, float or cyclic applications.
- Maintenance-free operation.
- Low self discharge.

SPECIFICATION

Nominal voltage	12V
Number of cell	6
Length(mm/inch)	395/15.6
Width(mm/inch)	110/4.33
Height(mm/inch)	286/11.3
Total Height(mm/inch)	286/11.3
Approx. Weight (kg/lbs)	32 Kg

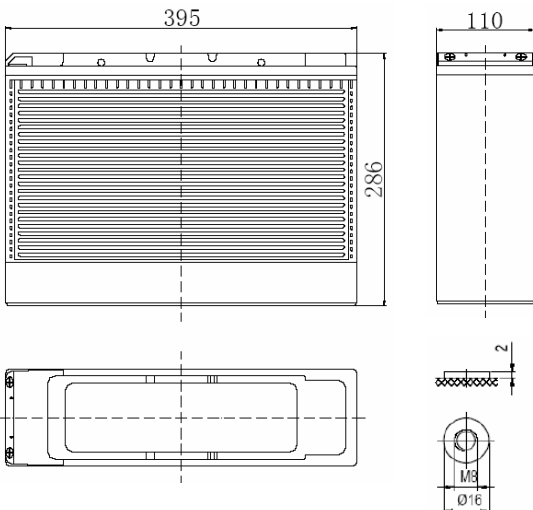

Performance Characteristics

Capacity 77°F(25°C)	100 hour rate (1.2A、11.1V)	120Ah
	20 hour rate (5.3A、10.8V)	106Ah
	10 hour rate (10A、10.8V)	100Ah
	1 hour rate (68A、9.6V)	68Ah
Internal Resistance	Full charged Battery 77°F(25°C): 8.5mΩ	
Operating Temperature Range	Discharge: -20~60°C	
	Charge: -10~60°C	
	Storage: -20~60°C	
Self-Discharge 3% of capacity declined per month at 20°C(average)		
Max. discharge current 77°F(25°C): 800A(5S)		
Charge (Constant Voltage)	Float: 13.38~13.68 V/77°F(25°C)	
	Cycle: 14.28~14.52 V/77°F(25°C)	
	Max. Current: 25A	

Discharge Constant Current (Amperes at 77°F25°C)

End Point Volts/Cell	10min	15min	30min	45min	1h	3h	5h	10h
1.60V	218	176	110	78.8	63.5	27.8	18.5	10.1
1.65V	201	165	106	76.4	61.5	27.1	18.1	10.1
1.70V	185	154	102	73.9	59.5	26.4	17.8	10.0
1.75V	169	143	97	71.6	57.5	25.7	17.2	10.0
1.80V	153	132	93	68	55.1	24.6	16.8	10.0

Discharge Constant Power (Watts at 77°F25°C)

End Point Volts/Cell	10min	15min	30min	45min	1h	2h	3h	5h
1.60V	380	319	206	150	121	70.1	52.3	36.5
1.65V	358	303	199	144	117	68.1	51.2	36.1
1.70V	337	286	195	140	115	66.4	50.1	35.8
1.75V	316	270	182	134	110	63.1	49.1	35.5
1.80V	294	254	170	128	103	62.3	47.8	34.6

(Note)The above characteristics data are average values obtained within three charge/discharge cycles not the minimum values.

