

TC12-100-G (12V100Ah/20hr)

Design Life: 12 years

Gel battery shows some distinctive advantages over flooded battery or AGM battery, such as super thermal stability, high deep discharge capability, good recovery from deep discharge, even if the battery is left discharged for three days, it will recover to 100% of capacity. With the above-mentioned advantages, the gel battery has long service life, specially suitable for motive power applications, such as golf trailer, srubber, folklift, etc. The deep discharge cycles increased 50% as compared with the AGM battery.

Battery Construction

Component	Positive plate	Negative plate	Container	Cover	Safety valve	Terminal	Separator	Electrolyte
Raw material	Lead dioxide	Lead	ABS	ABS	Rubber	Copper	PVC	Gelled acid

General Feature

- Nanometer SiO₂ and H₂SO₄ gelled electrolyte technology for efficiency gas recombination of up to 99% and freedom from electrolyte maintenance or water adding.
- Not restricted for air transport-complies with IATA/ICAO Special Provision A67.
- UL-recognized component.
- Can be mounted in any orientation.
- Computer designed lead, calcium tin alloy grid for high power density.
- Long service life, float or cyclic applications.
- Maintenance-free operation.
- Low self discharge.
- Case and cover available in both standard and flame restardant ABS.

SPECIFICATION

Nominal voltage 12V
 Number of cell 6
 Length(mm/inch) 328/12.9
 Width(mm/inch) 171/6.73
 Height(mm/inch) 214/8.43
 Total Height(mm/inch) 218/8.58
 Approx. Weight(kg/lbs) 30.0/66.0

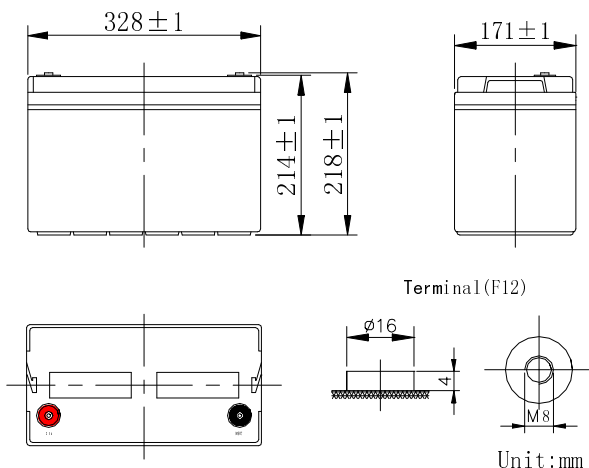

Performance Characteristics

Capacity 77°F(25°C)	100 hour rate (1.1A、 11.1V)	110Ah
	20 hour rate (5A、 10.5V)	100Ah
	10 hour rate (9.2A、 10.5V)	92Ah
	1 hour rate (58A、 9.6V)	58Ah
Internal Resistance	Full charged Battery77°F(25°C):10mΩ	
Operating Temperature Range	Discharge: -20~60°C	
	Charge: -10~60°C	
	Storage: -20~60°C	
Self-Discharge 3% of capacity declined per month at 20°C(average)		
Max. discharge current77°F(25°C): 800A(5S)		
Charge (Constant Voltage)	Float: 13.38~13.68 V/77° F(25°C)	
	Cycle:14.28~14.52 V/77°F(25°C) Max. Current: 25A	

Discharge Constant Current (Amperes at 77° F25 °C)

End Point Volts/Cell	5min	10min	15min	30min	1h	3h	5h	10h	20h
1.60V	292	200	164	92.9	58.0	25.2	16.8	9.40	5.25
1.65V	267	187	156	89.3	56.4	25.0	16.6	9.30	5.15
1.70V	245	172	148	86.6	54.5	24.8	16.5	9.20	5.10
1.75V	218	162	138	84.0	53.7	24.6	16.3	9.20	5.00
1.80V	193	148	129	82.2	52.7	24.5	16.0	9.10	4.95

Discharge Constant Power (watts at 77° F 25 °C)

End Point Volts/Cell	5min	10min	15min	30min	45min	1h	2h	3h	5h
1.60V	501	346	283	177	131	113	64.8	46.0	32.5
1.65V	457	328	278	171	127	111	63.7	45.3	32.3
1.70V		312	270	167	125	110	62.5	44.9	32.0
1.75V	390	295	259	162	123	106	61.3	44.5	31.9
1.80V	353	275	251	156	120	103	60.7	43.6	31.6

(Note)The above characteristics data are average values obtained Within three charge/discharge cycles not the minimum values.

