

● **Outer dimensions (mm)**

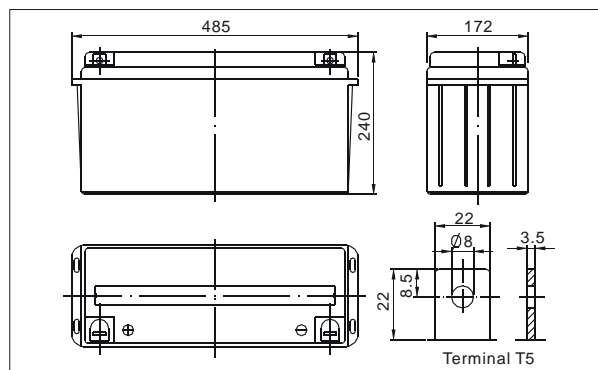

TianChang sealed lead-acid rechargeable battery (VRLA battery) is leak-proof and maintenance free. The Superiority of VRLA battery is derived from its uniquely efficient oxygen recombination technology. The oxygen evolved from the positive plates diffuses through the micro porous glass fiber mat to the negative plates where it is changed back to water by recombination reaction, eliminating the need for water addition. The result is a maintenance free battery.

● **Battery Construction**

Component	Positive plate	Negative plate	Container	Cover	Safety valve	Terminal	Separator	Electrolyte
Raw material	Lead dioxide	Lead	ABS	ABS	Rubber	Copper	Fiberglass	Sulfuric acid

● **General Features**

- Absorbent Glass Mat (AGM) technology for efficient gas recombination of up to 99% and freedom from electrolyte maintenance or water adding.
- Not restricted for air transport-complies with IATA/ICAO Special Provision A67.
- UL-recognized component.
- Can be mounted in any orientation.
- Computer designed lead, calcium tin alloy grid for high power density.
- Long service life, float or cyclic applications.
- Maintenance-free operation.
- Low self discharge.

● **Application**

- Electric powered vehicles
- Golf cars and buggies
- PDA equipment as laptop computer,
- Camera, phone sets, medical sets
- Power tools, Lawn mowers, vacuum cleaners
- Electric Powered Toys
- Wheel Chairs

● **Specifications**

Nominal Voltage		12V
Capacity (10 hr 25°C)		150Ah
Design Life		10 Years
Dimensions	Length	485 mm (19.09 inch)
	Width	172 mm (6.77 inch)
	Height	240 mm (9.45 inch)
	Total Height	240 mm (9.45 inch)
Approx. Weight		46 Kg
Capacity 25°C (77°F)	10 hr rate	150Ah
	3 hr rate	120Ah
	1 hr rate	97.5Ah
Internal Resistance (Full charged Battery at 25°C (77°F))		3.2 mΩ

Capacity affected by Temperature (20hr)	40°C	102%
	25°C	100%
	0°C	85%
	-15°C	65%
Self-Discharge at 25°C	3 month	Remaining capacity: 91%
	6 month	Remaining capacity: 82%
	12 month	Remaining capacity: 65%
Normal operating temperature		25°C ± 3°C (77°F ± 5°F)
Operating temperature range		-15°C ~ 50°C (5 ~ 122°F)
Float charging voltage (25°C)		13.6 to 13.8V
Cyclic charging voltage (25°C)		14.5 to 14.9V
Maximum charging current		45A
Terminal material		Copper
Maximum Discharge current		1200A (5sec)

Charge characteristic Curve for standby use

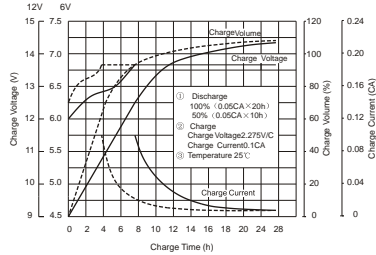

Discharge characteristic (25°C/77°F)

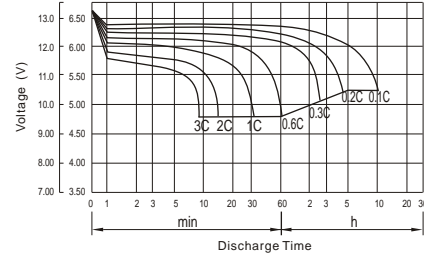

Relationship between charging voltage and temperature

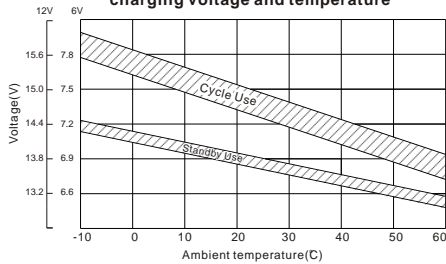

Self-discharge characteristic

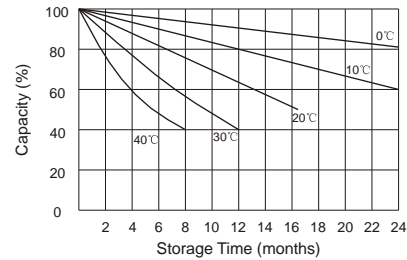

Temperature effects on float life

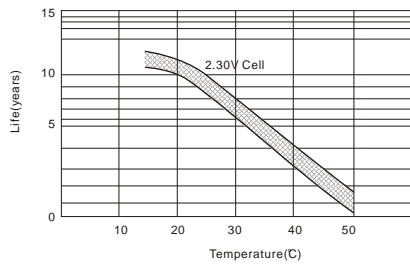

Temperature effects on capacity

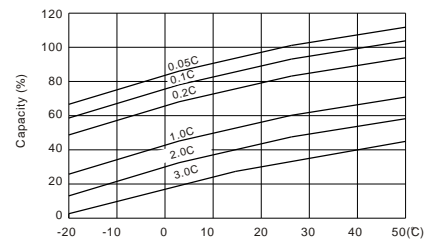

Life characteristics of Standby use

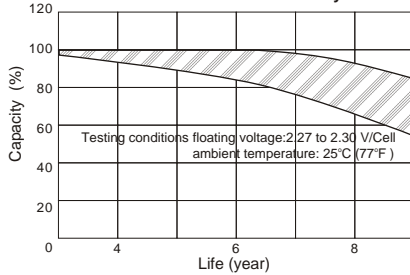

Cycle service life in relation to depth of discharge

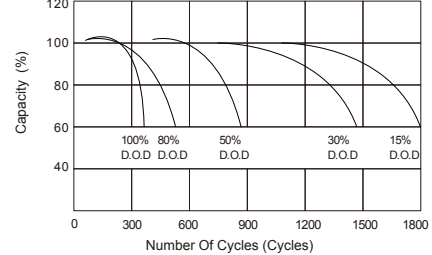

Discharge Constant Current (Amperes at 77°F/25°C)

F.V/Time	5MIN	10MIN	15MIN	30MIN	1HR	2HR	3HR	4HR	5HR	8HR	10HR	20HR
9.60V	382.1	297.0	231.5	156.8	92.63	56.64	39.15	32.40	26.52	18.63	15.75	8.332
10.0V	371.1	282.6	226.8	154.0	92.20	56.22	39.00	32.25	26.36	18.48	15.60	8.180
10.2V	360.1	272.6	223.2	151.2	91.34	55.79	38.70	32.10	26.21	18.33	15.45	8.029
10.5V	323.3	251.5	212.5	150.1	90.49	55.36	38.55	31.80	25.90	18.18	15.30	7.877
10.8V	291.8	229.4	195.9	147.5	88.35	54.37	37.50	31.05	25.43	17.88	15.15	7.726
11.1V	249.2	205.0	175.7	138.1	83.93	51.96	35.85	29.55	24.34	17.12	14.69	7.271

Discharge Constant Power (Watts at 77°F/25°C)

F.V/Time	5MIN	10MIN	15MIN	30MIN	1HR	2HR	3HR	4HR	5HR	8HR	10HR	20HR
9.60V	4031	3163	2547	1775	1070	667.6	465.9	386.2	316.4	222.5	188.3	99.90
10.0V	3952	3066	2506	1753	1068	664.1	466.1	385.7	315.6	221.4	187.1	98.16
10.2V	3907	2985	2477	1741	1060	660.1	464.0	384.9	314.5	220.0	185.4	96.34
10.5V	3557	2779	2363	1729	1050	655.3	462.2	381.3	310.8	218.1	183.6	94.53
10.8V	3239	2562	2184	1701	1031	646.9	449.6	372.6	305.1	214.5	181.8	92.71
11.1V	2845	2316	1966	1602	987	622.9	430.2	354.6	292.0	205.4	176.3	87.26

(Note) The above characteristics data are average values.