

● Outer dimensions (mm)

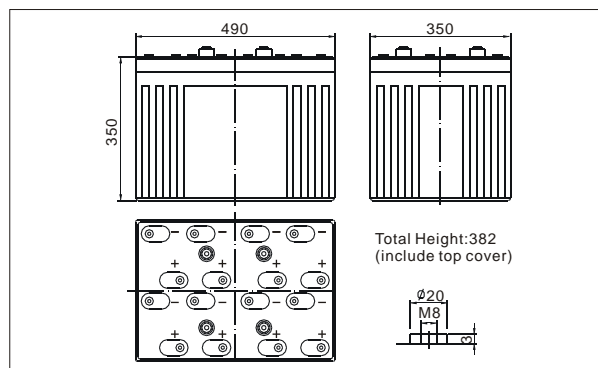

TianChang sealed lead-acid rechargeable battery (VRLA battery) is leak-proof and maintenance free. The Superiority of VRLA battery is derived from its uniquely efficient oxygen recombination technology. The oxygen evolved from the positive plates diffuses through the micro porous glassfiber mat to the negative plates where it is changed back to water by recombination reaction, eliminating the need for water addition. The result is a maintenance free battery.

● Battery Construction

Component	Positive plate	Negative plate	Container	Cover	Safety valve	Terminal	Separator	Electrolyte
Raw material	Lead dioxide	Lead	ABS	ABS	Rubber	Copper	Fiberglass	Sulfuric acid

● General Features

- Absorbent Glass Mat (AGM) technology for efficient gas recombination of up to 99% and freedom from electrolyte maintenance or water adding.
- Not restricted for air transport-complies with IATA/ICAO Special Provision A67.
- UL-recognized component.
- Can be mounted in any orientation.
- Computer designed lead, calcium tin alloy grid for high power density.
- Long service life, float or cyclic applications.
- Maintenance-free operation.
- Low self discharge.

● Application

- Medical Equipment
- Cable Television
- Control Equipment
- UPS
- Communication Equipment
- Emergency power System
- Security System

● Specifications

Nominal Voltage		2V
Capacity (10 hr 25°C)		2000Ah
Design Life		20 Years
Dimensions	Length	490 mm (19.29 inch)
	Width	350 mm (13.78 inch)
	Height	350 mm (13.78 inch)
	Total Height	382 mm (15.04inch)
Approx. Weight		119 Kg
Capacity 25°C (77°F)	10 hr rate	2000Ah
	3 hr rate	1600Ah
	1 hr rate	1300Ah
Internal Resistance (Full charged Battery at 25°C (77°F))		0.12m Ω
Capacity affected by Temperature (20hr)	40°C	102%
	25°C	100%
	0°C	85%
	-15°C	65%
Self-Discharge at 25°C	3 month	Remaining capacity: 91%
	6 month	Remaining capacity: 82%
	12 month	Remaining capacity: 65%
Normal operating temperature		25°C ± 3°C (77°F ± 5°F)
Operating temperature range		-15°C ~ 50°C (5 ~ 122°F)
Float charging voltage (25°C)		2.27 to 2.30V
Cyclic charging voltage (25°C)		2.42 to 2.48V
Maximum charging current		400A
Terminal material		Copper
Maximum Discharge current		12000A (5sec)

Charge characteristic Curve for standby use

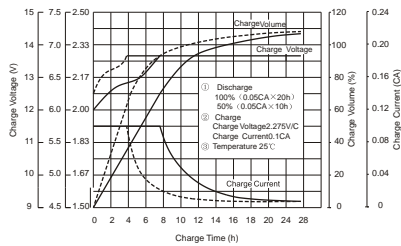

Discharge characteristic (25°C/77°F)

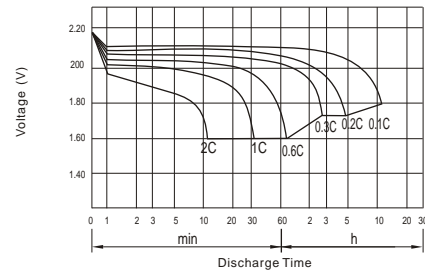

Relationship between charging voltage and temperature

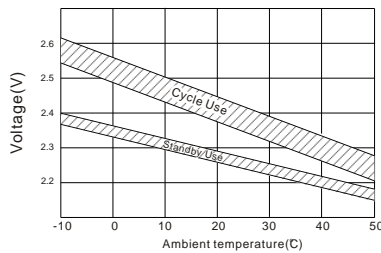

Self-discharge characteristic

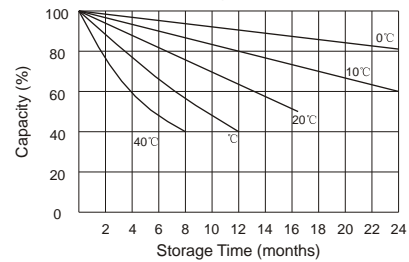

Temperature effects on float life

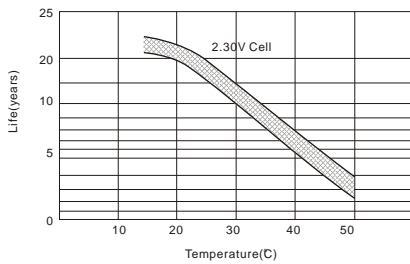

Temperature effects on capacity

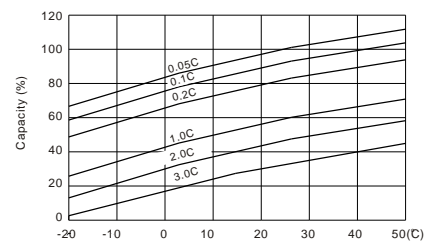

Life characteristics of Standby use

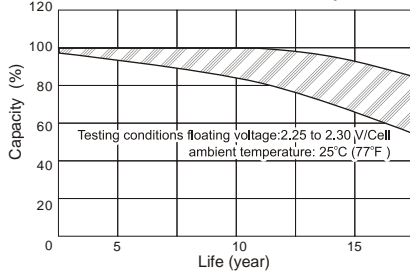

Battery Cycle life Vs. Depth of Discharge(DOD)

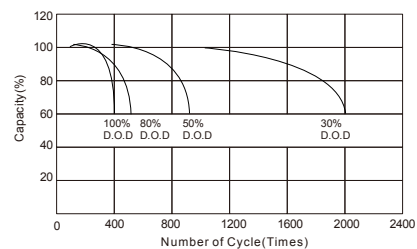

Discharge Constant Current (Amperes at 77°F/25°C)

End Point Volts/Cell	10min	15min	30min	45min	1h	3h	5h	10h
1.60V	3636	2734	2109	1505	1240	545	384	214
1.65V	3447	2603	2016	1445	1214	527	379	212
1.70V	3250	2468	1919	1381	1185	508	371	209
1.75V	3049	2329	1820	1315	1154	500	360	205
1.80V	2844	2190	1718	1247	1125	473	332	200

Discharge Constant Power (Watts at 77°F/25°C)

End Point Volts/Cell	10min	15min	30min	45min	1h	2h	3h	5h
1.60V	5754	4654	3543	2673	2206	1488	1018	706
1.65V	5422	4404	3365	2551	2130	1431	1001	701
1.70V	5084	4152	3185	2422	2052	1368	987	692
1.75V	4750	3892	3000	2290	2023	1338	966	678
1.80V	4416	3636	2812	2160	1908	1274	904	663

All mentioned characteristics data are average values.