

● Outer dimensions (mm)

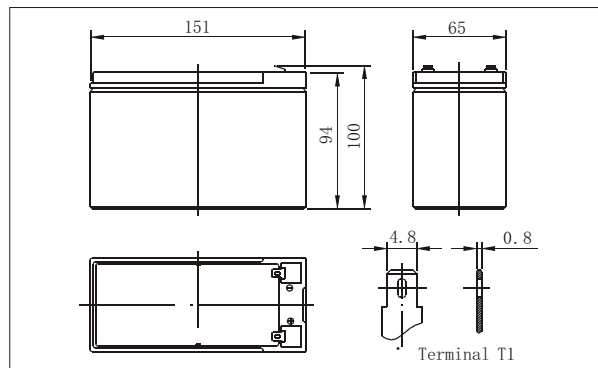

TianChang sealed lead-acid rechargeable battery (VRLA battery) is Leak-proof and Maintenance free. The Superiority of VRLA battery is derived from its uniquely efficient oxygen recombination technology. The oxygen Evolved from the positive plates diffuses through the micro porous glass fiber matto the negative plates where it is changed back to water by recombination reaction, Eliminating the need for Water addition .The result is a maintenance free battery.

● Battery Construction

Component	Positive plate	Negative plate	Container	Cover	Safety valve	Terminal	Separator	Electrolyte
Raw material	Lead dioxide	Lead	ABS	ABS	Rubber	Copper	Fiberglass	Sulfuric acid

● General Features

- Absorbent Glass Mat (AGM) Technology for efficient gas recombination of upto 99% and freedom from electrolyte maintenance or water adding.
- Not restricted for air transport-complies with IATA/ICAO Special Provision A67.
- UL-recognized component.
- Can be mounted in any orientation.
- Computer designed lead, calcium tinalloy grid for high power density
- Long service life, float or cyclic applications.
- Maintenance-free operation.
- Low self discharge.

● Application

- Alarm System
- Medical Equipment
- Cable Television
- Control Equipment
- UPS
- Communication Equipment
- Toys
- Emergency power System
- Power Tools
- Security System

● Specifications

Nominal Voltage	12V	
Capacity (20 hr 25°C)	9Ah	
Design Life	5 Years	
Dimensions	Length	151mm (5.94 inch)
	Width	65mm (2.56 inch)
	Height	94 mm (3.70 inch)
	Total Height	100mm (3.94 inch)
Approx. Weight	2.60 Kg (5.72lbs)	
Capacity 25°C (77°F)	20 hr rate	9Ah
	10 hr rate	8.37Ah
	5 hr rate	7.65Ah
	1 hr rate	5.4Ah
Internal Resistance (Full charged Battery at 25°C (77°F))	16m Ω	

Capacity affected by Temperature (20hr)	40 °C	102%
	25 °C	100%
	0 °C	85%
	-15 °C	65%
Self-Discharge at 25°C	3 month	Remaining capacity: 91%
	6 month	Remaining capacity: 82%
	12 mon th	Remaining capacity: 65%
Normal operating temperature	25 °C ±3 °C (77°F ±5 °F)	
Operating temperature range	-15 °C ~50 °C (5 ~122 °F)	
Float charging voltage (25°C)	13.6 to 13.8V	
Cyclic charging voltage (25°C)	14.5 to 14.9V	
Maximum chaging current	3.60A	
Terminal material	Copper	
Maximum Discharge current	135A (5sec)	

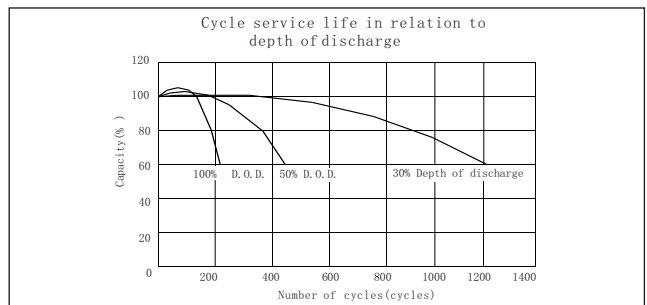
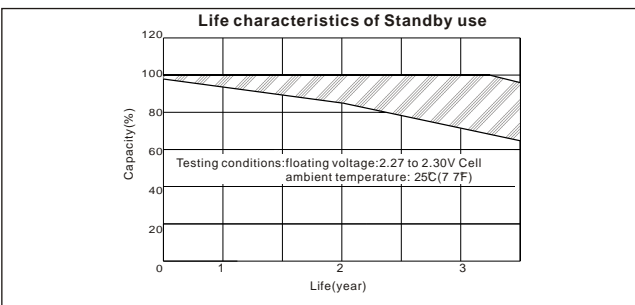
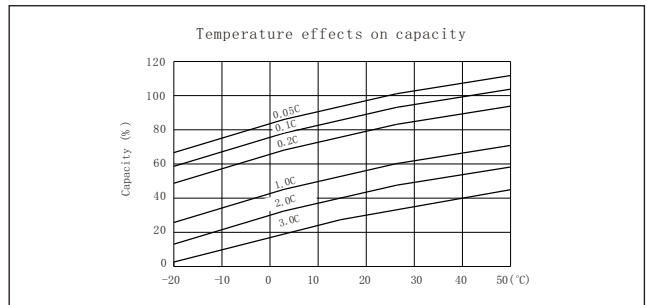
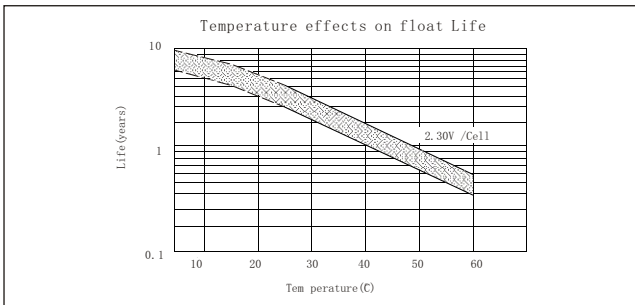
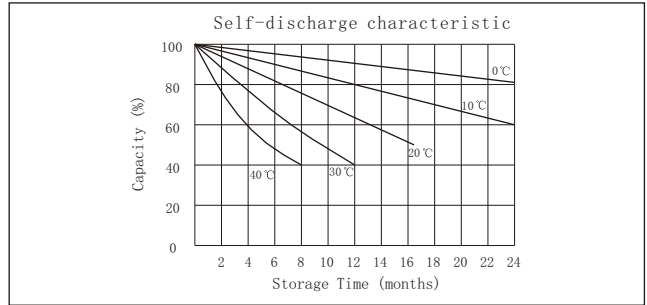
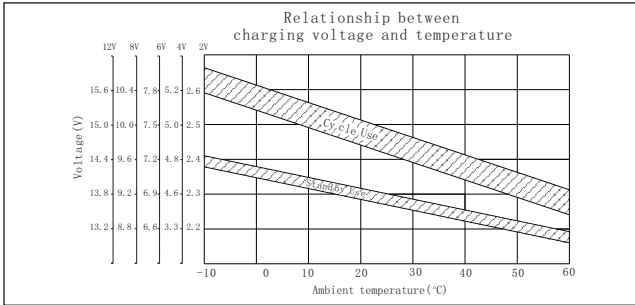
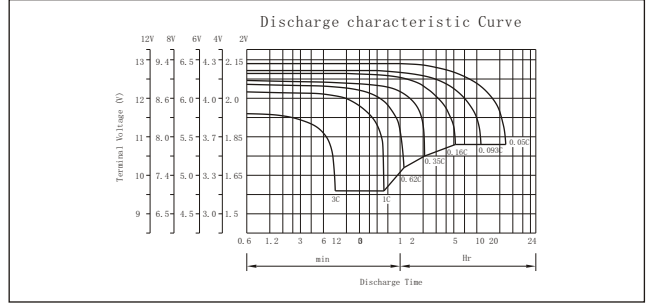
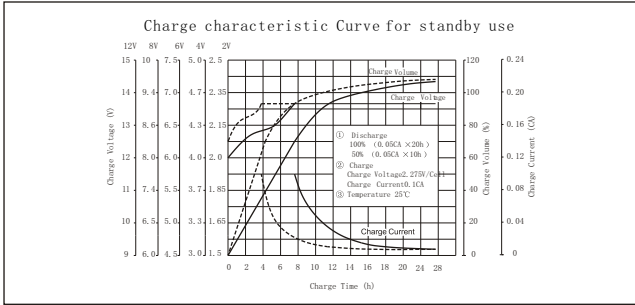

Constant current discharge ratings-amperes at 25

End Point Volts/Cell	5min	10min	15min	30min	1h	3h	5h	10h	20h
1.60V	36.6	24.7	18.9	10.4	5.89	2.39	1.51	0.912	0.466
1.65V	35.1	23.8	18.3	10.0	5.61	2.31	1.49	0.892	0.462
1.70V	33.1	22.9	17.9	9.59	5.34	2.23	1.46	0.873	0.456
1.75V	31.1	22.0	17.2	9.20	5.07	2.14	1.44	0.854	0.450
1.80V	29.0	21.0	16.7	8.82	4.96	2.04	1.42	0.834	0.442

Constant power discharge ratings-watts at 25

End Point Volts/Cell	5min	10min	15min	30min	1h	3h	5h	10h	20h
1.60V	67.6	46.0	35.3	19.5	11.1	4.53	2.88	1.75	0.90
1.65V	64.6	44.0	34.1	18.6	10.5	4.36	2.82	1.70	0.89
1.70V	60.5	42.1	33.1	17.8	9.99	4.20	2.76	1.66	0.87
1.75V	56.5	40.2	31.7	17.0	9.43	3.99	2.72	1.61	0.86
1.80V	52.2	38.1	30.5	16.2	9.18	3.79	2.65	1.57	0.84