

● **Outer dimensions (mm)**

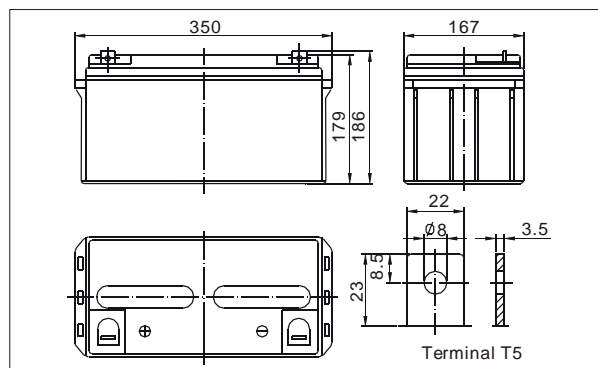

TianChang sealed lead-acid rechargeable battery (VRLA battery) is leak-proof and maintenance free. The Superiority of VRLA battery is derived from its uniquely efficient oxygen recombination technology. The oxygen evolved from the positive plates diffuses through the micro porous glass fiber mat to the negative plates where it is changed back to water by recombination reaction, eliminating the need for water addition. The result is a maintenance free battery.

● **Battery Construction**

Component	Positive plate	Negative plate	Container	Cover	Safety valve	Terminal	Separator	Electrolyte
Raw material	Lead dioxide	Lead	ABS	ABS	Rubber	Copper	Fiberglass	Sulfuric acid

● **General Features**

- Absorbent Glass Mat (AGM) technology for efficient gas recombination of up to 99% and freedom from electrolyte maintenance or water adding.
- Not restricted for air transport-complies with IATA/ICAO Special Provision A67.
- UL-recognized component.
- Can be mounted in any orientation.
- Computer designed lead, calcium tin alloy grid for high power density.
- Long service life, float or cyclic applications.
- Maintenance-free operation.
- Low self discharge.

● **Application**

- Alarm System
- Medical Equipment
- Cable Television
- Control Equipment
- UPS
- Communication Equipment
- Toys
- Emergency power System
- Power Tools
- Security System

● **Specifications**

Nominal Voltage		12V
Capacity (10 hr 25°C)		65Ah
Design Life		10 Years
Dimensions	Length	350 mm (13.78 inch)
	Width	167 mm (6.57inch)
	Height	179 mm (7.05 inch)
	Total Height	186 mm (7.32 inch)
Approx. Weight		20.5 Kg
Capacity 25°C (77°F)	10 hr rate	65Ah
	3 hr rate	52Ah
	1 hr rate	42.25Ah
Internal Resistance (Full charged Battery at 25°C (77°F))		6.0m Ω

Capacity affected by Temperature (20hr)	40°C	102%
	25°C	100%
	0°C	85%
	-15°C	65%
Self-Discharge at 25°C	3 month	Remaining capacity: 91%
	6 month	Remaining capacity: 82%
	12 month	Remaining capacity: 65%
Normal operating temperature		25°C ± 3°C (77°F ± 5°F)
Operating temperature range		-15°C ~ 50°C (5 ~ 122°F)
Float charging voltage (25°C)		13.60 to 13.80V
Cyclic charging voltage (25°C)		14.50 to 14.90V
Maximum charging current		19.5A
Terminal material		Copper
Maximum Discharge current		650A (5sec)

**Charge characteristic Curve for standby use**

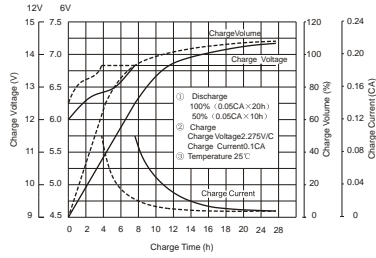

**Discharge characteristic (25°C/77°F)**

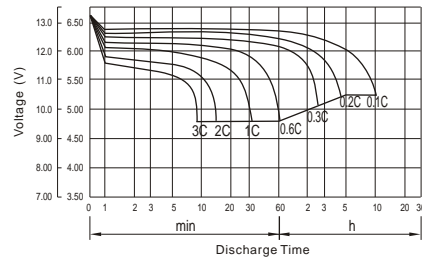

**Relationship between charging voltage and temperature**

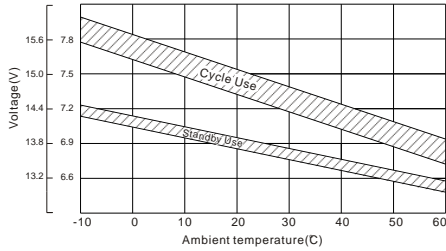

**Self-discharge characteristic**

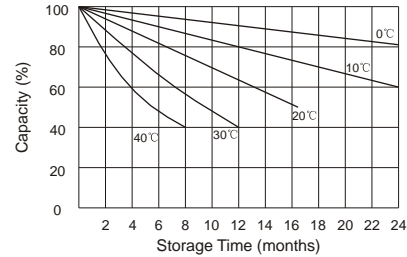

**Temperature effects on float life**

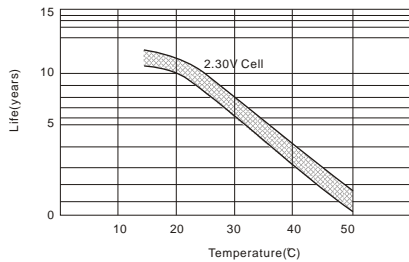

**Temperature effects on capacity**

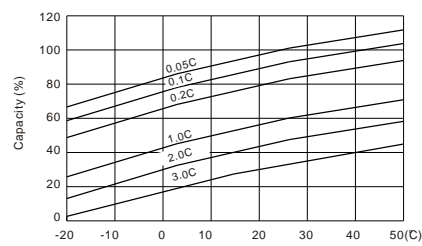

**Life characteristics of Standby use**

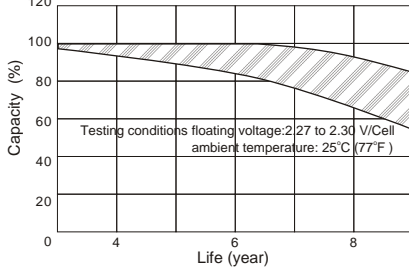

**Cycle service life in relation to depth of discharge**

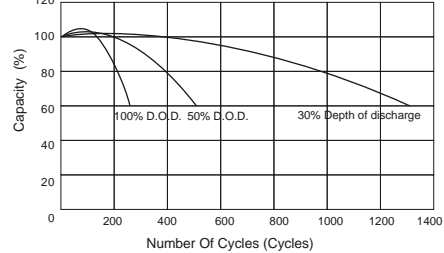

**Discharge Constant Current (Amperes at 77°F/25°C)**

F.V/Time	5MIN	10MIN	15MIN	30MIN	1HR	2HR	3HR	4HR	5HR	8HR	10HR	20HR
9.60V	217.8	160.4	125.0	76.18	42.25	25.27	17.45	14.45	12.17	8.312	6.894	3.678
10.0V	211.5	152.6	122.4	74.86	42.06	25.08	17.38	14.39	12.10	8.244	6.828	3.612
10.2V	205.2	147.2	120.5	73.47	41.67	24.89	17.25	14.32	12.02	8.176	6.761	3.545
10.5V	184.3	135.8	114.7	72.92	41.28	24.70	17.18	14.19	11.88	8.109	6.695	3.478
10.8V	166.3	123.9	105.8	71.67	40.30	24.25	16.71	13.85	11.67	7.974	6.629	3.411
11.1V	142.0	110.7	94.87	67.10	38.29	23.18	15.98	13.18	11.17	7.636	6.430	3.210

**Discharge Constant Power (Watts at 77°F/25°C)**

F.V/Time	5MIN	10MIN	15MIN	30MIN	1HR	2HR	3HR	4HR	5HR	8HR	10HR	20HR
9.60V	2298	1708	1363	854.8	488.2	297.8	207.6	172.3	145.2	99.24	82.38	44.10
10.0V	2252	1655	1341	844.3	487.1	296.2	207.7	172.1	144.8	98.76	81.86	43.34
10.2V	2227	1612	1326	838.3	483.3	294.4	206.8	171.7	144.3	98.12	81.14	42.54
10.5V	2027	1501	1265	832.5	478.9	292.3	206.0	170.1	142.6	97.31	80.34	41.73
10.8V	1846	1383	1169	819.2	470.1	288.6	200.4	166.2	140.0	95.69	79.54	40.93
11.1V	1622	1251	1052	771.6	450.0	277.9	191.7	158.2	134.0	91.63	77.16	38.52

(Note) The above characteristics data are average values.