

● **Outer dimensions (mm)**

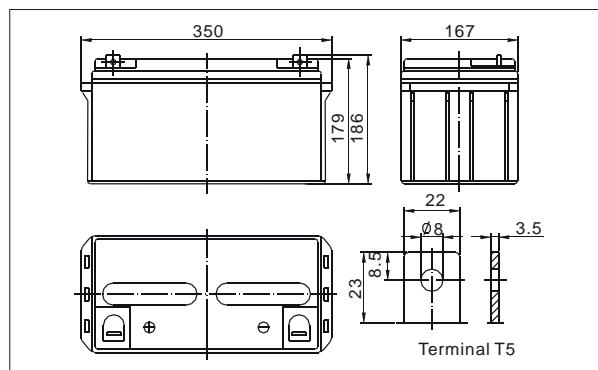

TianChang sealed lead-acid rechargeable battery (VRLA battery) is leak-proof and maintenance free. The Superiority of VRLA battery is derived from its uniquely efficient oxygen recombination technology. The oxygen evolved from the positive plates diffuses through the micro porous glass fiber mat to the negative plates where it is changed back to water by recombination reaction, eliminating the need for water addition. The result is a maintenance free battery.

● **Battery Construction**

Component	Positive plate	Negative plate	Container	Cover	Safety valve	Terminal	Separator	Electrolyte
Raw material	Lead dioxide	Lead	ABS	ABS	Rubber	Copper	Fiberglass	Sulfuric acid

● **General Features**

- Absorbent Glass Mat (AGM) technology for efficient gas recombination of up to 99% and freedom from electrolyte maintenance or water adding.
- Not restricted for air transport-complies with IATA/ICAO Special Provision A67.
- UL-recognized component.
- Can be mounted in any orientation.
- Computer designed lead, calcium tin alloy grid for high power density.
- Long service life, float or cyclic applications.
- Maintenance-free operation.
- Low self discharge.

● **Application**

- Alarm System
- Medical Equipment
- Cable Television
- Control Equipment
- UPS
- Communication Equipment
- Toys
- Emergency power System
- Power Tools
- Security System

● **Specifications**

Nominal Voltage		12V
Capacity (10 hr 25°C)		80Ah
Design Life		10 Years
Dimensions	Length	350 mm (13.78 inch)
	Width	167 mm (6.57inch)
	Height	179 mm (7.05 inch)
	Total Height	186 mm (7.32 inch)
Approx. Weight		23.5 Kg (52.92lbs)
Capacity 25°C (77°F)	10 hr rate	80Ah
	3 hr rate	64Ah
	1 hr rate	52Ah
Internal Resistance (Full charged Battery at 25°C (77°F))		5.5m Ω

Capacity affected by Temperature (20hr)	40°C	102%
	25°C	100%
	0°C	85%
	-15°C	65%
Self-Discharge at 25°C	3 month	Remaining capacity: 91%
	6 month	Remaining capacity: 82%
	12 month	Remaining capacity: 65%
Normal operating temperature		25°C ± 3°C (77°F ± 5°F)
Operating temperature range		-15°C ~ 50°C (5 ~ 122°F)
Float charging voltage (25°C)		13.60 to 13.80V
Cyclic charging voltage (25°C)		14.50 to 14.90V
Maximum charging current		24A
Terminal material		Copper
Maximum Discharge current		800A (5sec)

**Charge characteristic Curve for standby use**

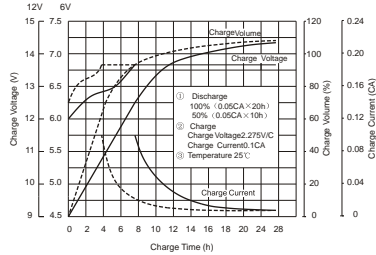

**Discharge characteristic (25°C/77°F)**

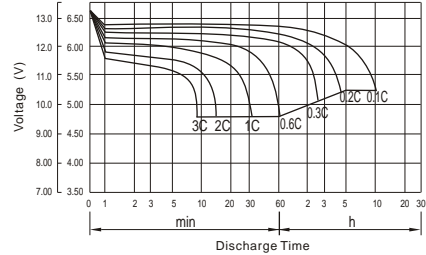

**Relationship between charging voltage and temperature**

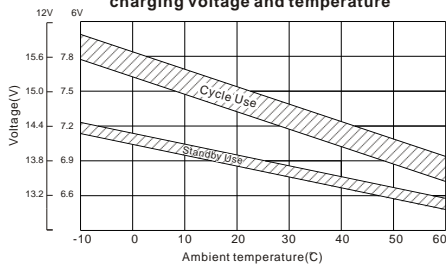

**Self-discharge characteristic**

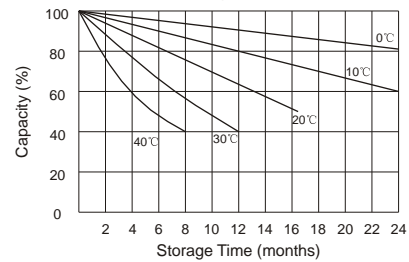

**Temperature effects on float life**

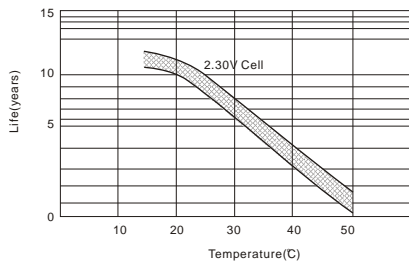

**Temperature effects on capacity**

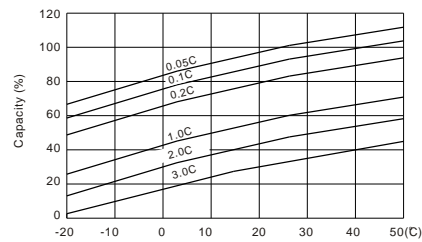

**Life characteristics of Standby use**

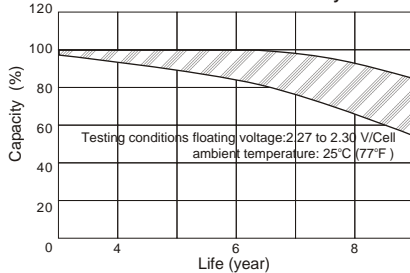

**Cycle service life in relation to depth of discharge**

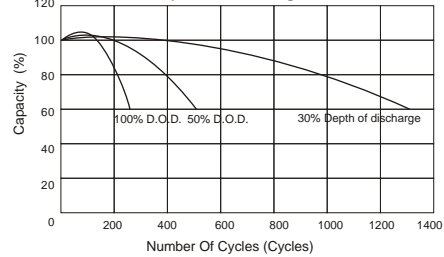

**Discharge Constant Current (Amperes at 77°F25°C)**

F.V/Time	5MIN	10MIN	15MIN	30MIN	1HR	2HR	3HR	4HR	5HR	8HR	10HR	20HR
9.60V	268.0	197.4	153.8	93.8	52.0	31.1	21.5	17.8	15.0	10.2	8.48	4.53
10.0V	260.3	187.8	150.7	92.1	51.8	30.9	21.4	17.7	14.9	10.1	8.40	4.44
10.2V	252.6	181.2	148.3	90.4	51.3	30.6	21.2	17.6	14.8	10.1	8.32	4.36
10.5V	226.8	167.2	141.2	89.7	50.8	30.4	21.1	17.5	14.6	10.0	8.24	4.28
10.8V	204.7	152.4	130.2	88.2	49.6	29.9	20.6	17.0	14.4	9.8	8.16	4.20
11.1V	174.8	136.2	116.8	82.6	47.1	28.5	19.7	16.2	13.7	9.4	7.91	3.95

**Discharge Constant Power (Watts at 77°F25°C)**

F.V/Time	5MIN	10MIN	15MIN	30MIN	1HR	2HR	3HR	4HR	5HR	8HR	10HR	20HR
9.60V	2828	2102	1677	1052	601	367	256	212	179	122	101	54.3
10.0V	2772	2037	1650	1039	599	365	256	212	178	122	101	53.3
10.2V	2741	1984	1632	1032	595	362	255	211	178	121	100	52.4
10.5V	2495	1847	1556	1025	589	360	254	209	175	120	99	51.4
10.8V	2272	1703	1439	1008	579	355	247	205	172	118	98	50.4
11.1V	1996	1539	1295	950	554	342	236	195	165	113	95	47.4

(Note)The above characteristics data are average values.